PLEASE RETAIN



Solis Double Sided Insert



INSTALLATION AND OPERATING INSTRUCTIONS

This appliance is hot while in operation and retains its heat for a long period of time after use. Children, aged or infirm persons should be supervised at all times and should not be allowed to touch the hot working surfaces while in use or until the appliance has thoroughly cooled.

When using the stove in situations where children, aged and/or infirm persons are present a fireguard must be used to prevent accidental contact with the stove. The fireguard should be manufactured in accordance with BS 8423:2010.

TABLE OF CONTENTS

	PAGE NO.
1. Stanley Stove Warranty	3
2. Installation Checklist	4
3. Important Operation/ Maintenance Notes	5
4. Installation & Operating Instructions	6
5. General	6
6. Electrical Supply	6
7. Flues	6
8. Chimney	6
9. Fitting Instructions	7
10. Down Draughts	8
11. Ventilation & Combustion Air Requirements	9
12. External Ducted Air	9
13. Heat Recovery Ventilation	10
14. Location	10
15. Clearance To Combustibles	10
16. Floor Protection	10
17. Warm Air Ducting System	11
18. Position of Warm Air Duct	11
19. Fitting the Warm Air Duct to the Stove	11
20. Stove Dimensions	12
21. Commissioning and Handover	12
22. Operation	12
23. Air Controls	13
24. Fan Operation	13
25. Recommended Fuels	13
26. Technical Data	14
27. Lighting	14
28. Lighting The Stove	14
29. Refuelling	15
30. Slow Burning	15
31. Disposal of Ashes	15
32. Monthly Maintenance	15
33. Periodic Maintenance	16
34. Chimney Cleaning	16
35. Glass Cleaning	16
36. Cleaning a Matt Black/ Senotherm Stove	16
37. Prolonged Periods of Non Use	16
38. Fire Safety	17
39. Glass Replacement	17
40. CO Alarm	17
41. Electrical Diagram	18
42. Exploded View	19



STANLEY STOVE WARRANTY

CONDITIONS OF WARRANTY

Your Stanley Stove is guaranteed against any part that fails (under normal operating conditions) as detailed in the following table with timelines specified from the date of installation of the appliance. If the unit is not installed within six months of date of purchase, the warranty will commence six months from the date of purchase.

Warranty Period	Parts Covered (Parts & Labour unless Stated)
Up to 1 Year	<ul style="list-style-type: none">• Refractory materials (supply only)• Rope seals, glass seals and cement seals.• Surface Finish on Seno models.• Grates and fire bars.• Ceramic glass is covered for Thermal breakage (supply only).• Rust (if reported before installation)• Aesthetic Damage (provided reported on date of receipt)
Up to 5 Years	<ul style="list-style-type: none">• All external castings (excluding impact damage or damage caused by overfiring). Pictures of damage must be submitted to WS Service Department.

All warranty claims must be reported to the Waterford Stanley Service Department and must be submitted with the product serial number (located on the underside of the ashpan), date of purchase, proof of purchase (if requested) and details of the specific nature of the problem.

The warranty is given only to the original consumer/purchaser only and is non-transferable. The appliance must be installed by a suitable qualified person and installed as per the requirements of the manual. Failure to comply with the Installation Requirements or Building Regulations will void your warranty. Waterford Stanley reserve the right to replace any part due to manufacturing defect that fails within the warranty period under the terms of the warranty. The unit must be used for normal domestic purposes only and in accordance with manufacturer's operation instructions.

LIMITS OF LIABILITY

The warranty does not cover:

- * Special, incidental or consequential damages, injury to persons or Property, or any other consequential loss.
- * Any issue caused by negligence, misuse, abuse or circumstances beyond Waterford Stanley's control.
- * Any issue with wear and tear, modification, alteration, or servicing by anyone other than an authorized service engineer.
- * Installation and operational related problems such as draught related issues external to the stove, inadequate venting or ventilation, excessive flue offsets, negative air pressure caused by insufficient burning of improper fuel.
- * Damage caused to the unit while in transit.
- * Stress fractures on bricks.
- * Rust on cast iron parts unless reported prior to unit being installed.
- * Aesthetic damage, rust & missing parts on units purchased off display.

Note: Adequate clearance must be maintained around the appliance to ensure the ease of part removal in the possible event of their damage/failure. Waterford Stanley are not responsible for any costs incurred in the removal of items installed in the vicinity of the appliance that have to be moved to facilitate a part replacement.

INSTALLATION CHECK LIST

Tick

Flue System

1. Minimum Flue Height of 4.6 metres (15 feet).
2. Appliance should be connected to a minimum of 1.8 metres (6 feet) of 150mm (6") flue pipe.
3. Any horizontal flue run should not exceed 150mm (6")
4. All flue pipework passing through walls must be sleeved & adequately insulated in line with current Building Regulations.
5. Appliance should be connected to a chimney of less than 200mm (8") in diameter (otherwise the chimney must be lined with a 6" flue liner).
6. The chimney/ flue termination must be located in accordance with building regulations part J.
7. The chimney serving this appliance should not serve any other appliance.
8. Access should be provided to the chimney serving the appliance to allow for cleaning. (This can be done through the stove).
9. It is a requirement by Building Regulations to have a carbon monoxide alarm fitted to any room with a solid fuel appliance.

Location

10. Clearance to combustible materials must be adhered to as described in the Clearance to Combustible section.
11. The stove must be installed in a solid non combustible recess with a hearth or suitable non combustible floor protector that extends 225mm to the front of the appliance and 150mm to either side.

Ventilation & Combustion Air Requirements

12. The room in which the appliance is located should have an air vent of adequate size to support correct combustion (see Ventilation & Combustion Air Requirement Section for specific details).
13. The stove must not be installed in the same room as an extractor fan.



IMPORTANT OPERATION / MAINTENANCE NOTES

Now that your Stanley Woodburning Stove is installed and no doubt you are looking forward to the many comforts it will provide, we would like to give you some tips on how to get the best results from your stove.

1. We would like if you could take some time to read the operating instructions/hints, which we are confident, will be of great benefit to you.
2. Do not burn fuel with a high moisture content, such as a damp or unseasoned timber. This will only result in a build up of tar in the stove and in the chimney.
3. **IMPORTANT:** The first few fires should be relatively small to permit the refractory to set properly and season the stove. During these firings it is recommended to ventilate the room as an unpleasant (not toxic) odour may be emitted as the paint is completing curement.
4. **Inspect the flue-ways of the stove weekly and ensure that there are no blockages. Check flue ways before lighting especially after a shut down period. Please see chimney cleaning section.**
5. Never allow a build up of ashes in the ash pan, as this will cause the grate to burn out prematurely.
6. Avoid slow burning of damp or unseasoned timber as this will result in tarring flue ways and chimney.
7. Allow adequate air ventilation to ensure plenty of air for combustion.
8. Do not burn rubbish/household plastic.
9. Clean the chimney at least twice a year.
10. Regular cleaning of the glass will prevent permanent staining. Clean with soapy water when cool.
11. Keep all combustible materials a safe distance away from unit, please see section for clearances to combustibles.
12. Never use aerosol spray near the appliance when it is in operation.
13. For safety reasons never leave children or the elderly unaccompanied while stove is in use.
14. Avoid contact with the appliance when in use as the stove reaches very high operating temperatures.
15. This appliance should be regularly maintained by a competent service engineer.

INSTALLATION & OPERATING INSTRUCTIONS

GENERAL

When installing, operating and maintaining your Solis stove, respect basic standards of fire safety. Read these instructions carefully before commencing the installation. Failure to do so may result in damage to persons and property. Consult your local Municipal office and your insurance representative to determine what regulations are in force. Save these instructions for future reference.

Please note that it is a legal requirement under England & Wales Building Regulations that the installation of the stove is either carried out under Local Authority Building Control approval or is installed by a Competent Person registered with a Government approved Competent Persons Scheme. HETAS Ltd operate such a scheme and a listing of their Registered Competent Persons can be found on their website at www.hetas.co.uk.

Special care must be taken when installing the stove such that the requirements of the Health & Safety at Work Act are met.

Handling

Adequate facilities must be available for loading, unloading and site handling.

Fire Cement

Some types of fire cement are caustic and should not be allowed to come into contact with the skin. In case of contact with the skin wash immediately with plenty of water.

Asbestos

This stove contains no asbestos. If there is a possibility of disturbing any asbestos in the course of installation then please seek specialist guidance and use appropriate protective equipment.

Metal Parts

When installing or servicing this stove care should be taken to avoid the possibility of personal injury.

“IMPORTANT WARNING”

This stove must not be installed into a chimney that serves any other heating appliance.

The complete installation must be done in accordance with current Standards and Local Codes. It should be noted that the requirements and these publications may be superseded during the life of this manual.

Please refer to the current standards, BS EN 15287-1:2007 Design, Installation and Commissioning of chimneys. BS EN 14336:2004: Heating Systems in Buildings. Installation & Commissioning of Water Based Heating Systems. BS EN 12828: 2003; Heating Systems in Buildings. Design of Water Based Heating Systems. BS EN 12831: 2003; Heating Systems in Buildings. method for calculation of the design heat load.

Your Solis stove is supplied with the following items:

- Ashpan
- Glove
- Operating Tool
- External Air Connection
- Warm Air Duct Spigot x 2
- Glass Frames x 2
- Flue Adaptor
- Fan Switch Cut-Out Blank

ELECTRICAL SUPPLY

All wiring external to the appliance must conform to the current BS 7671 (UK) BS 7462 Safety Document 635: ETC Part 1, Section 5.4.6 and The Electricity at Work Regulations.

This unit requires a 220V-240V 50L/2 supply connection of the appliance and any system controls to the mains supply must be through a fused double pole switch having contact separation of at least 3mm with a fuse rated at 3 amp and located in a readily accessible position close to the appliance. Connection should be made through the cable supplied and if required the cable must only be extended/ replaced with a similar sized cable that is silicon-coated and heat resistant to 180°C (365°F).

FLUES

Flues should be vertical wherever possible and where a bend is necessary, it should not make an angle of more than 45° with the vertical. Horizontal flue runs should be avoided in order to minimise flue resistance and to make sweeping easier it is recommended to use 2 x 45° bends rather than a 90° bend.

CHIMNEY

Do not connect to a chimney serving another appliance.

The stove is a radiant room heater and must be connected to a chimney of the proper size and type. The chimney must have a cross-sectional area of at least 28 square inches 17660sq. mm or a diameter of at least 6” (150mm). It is best to connect to a chimney of the same size, as connection to a larger size may result in a somewhat less draught.

A flue that has proved to be unsatisfactory, particularly with regard to down draught should not be used for venting this appliance until it has been examined and any faults corrected. An existing masonry chimney should be inspected and if necessary repaired by a competent mason or relined using an approved lining system.

The stove must be connected to a chimney with a minimum continuous draught of 0.06 w.g. Poor draught conditions will result in poor performance.

All register plates, restricter plates, damper etc., which could obstruct the flue at a future date should be removed before connecting this appliance.

If connecting to an existing chimney with a flue diameter of more than 8" it is recommended to line the flue using a suitable stainless steel flue liner.

Where a masonry chimney is not available a proprietary type of 6"/150mm - twin wall, fully insulated pipe may be used. The pipe must terminate at a point not lower than the main ridge of adjacent outside obstructions. With such installation, access to the chimney must be provided for cleaning purposes.

A chimney / flue termination must be located to minimise wind effects, a basic guide is that the distance from the termination to the roof should be at least 2300mm when measured horizontally and at least 1000mm when measured vertically, (see Fig.1). In circumstances where there are adjoining buildings/ structures/ roof openings there are additional requirements, please refer to building regulations part J.

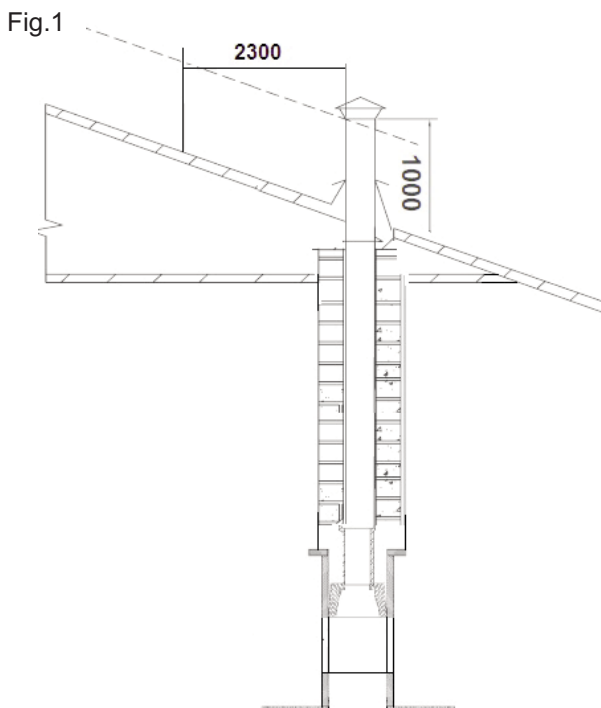

FITTING INSTRUCTIONS

The stove is designed to allow the chimney to be cleaned through the stove.

Step 1

Ensure the opening is suitable for fitting of the stove. (See Fig. 2)

Fig.2

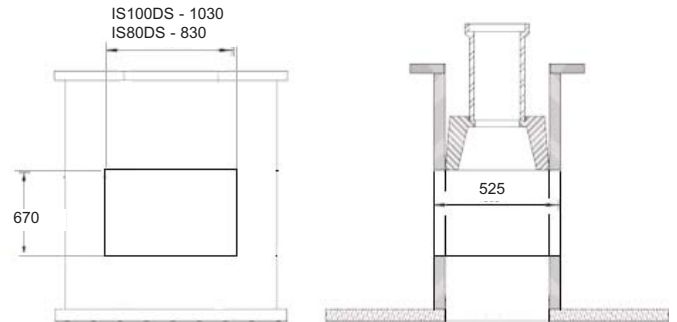

Step 2

Ensure the area on which the stove will be seated is level.

Step 3

Ensure that access is available to fit the flue spigot, flue adaptor and flue connection pipes subsequent to fitting the unit in its final position. To achieve this it may be necessary to fit an inspection hatch in the chimney structure above or to the side of the unit.

Step 4

Fit the stove in position so that the edge of the shell is flush with the wall on both sides.

Step 5

Complete the flue installation sealing all joints with appropriate fire cement.

Step 6

Complete the Electrical connection to the appliance (See Electrical Supply)

Step 7

Remove the fire door by opening the door slightly & lifting it up to detach from the bottom hinge (see Fig. 3).

Fig.3



Step 8

Loosen the two screws to remove the fan cover plate (see Fig 4).

Step 9

Disconnect the fan operation switch from the electrical harness.

Step 10

Fix the switch into the cut-out on the RHS of the glass frame and reconnect the electrical harness as shown in Fig. 5.

Fig.4

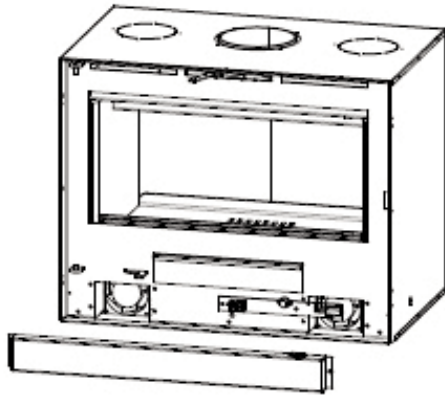
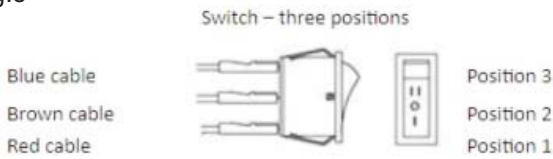

Fig.5



Step 11

Fit the glass frame onto the body of the unit & secure in place using the self tapping screws (see Fig. 6).

NOTE:

THE FRAME MUST NOT BE RECESSED INTO THE WALL AS CLEARANCE IS REQUIRED TO ALLOW FOR THE AIR INTAKE FOR THE VENTILATION FANS.

Fig.6

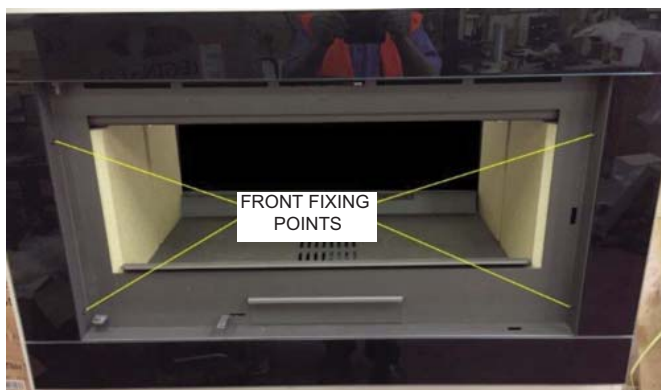

Step 12

Refit the fire door.

Step 13

Repeat steps 7-12 for the second glass frame with the blank fan switch cut out blank fitted instead of the three position switch.

DOWN DRAUGHTS

However well designed constructed and positioned, the satisfactory performance of the flue can be adversely affected by down draught caused by nearby hills, adjacent tall buildings or trees. These can deflect wind to blow directly down the flue or create a zone of low pressure over the terminal.

A suitable terminal or cowl will usually effectively combat direct down blow but no cowl is likely to prevent down draught due to a low pressure zone. (See Fig.7).

Fig.7

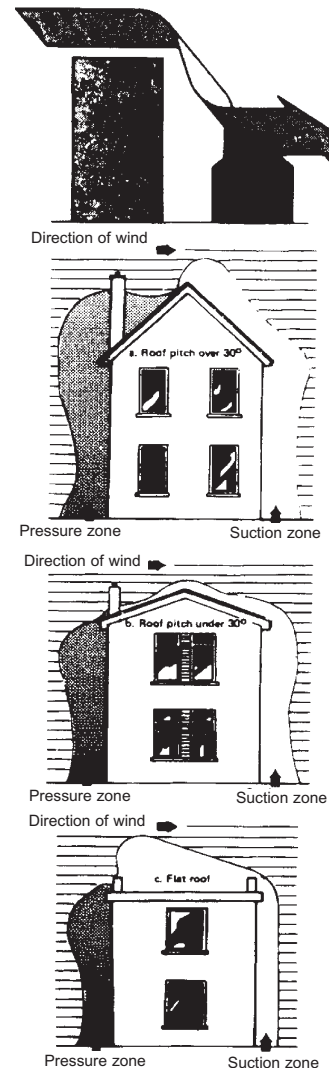

VENTILATION & COMBUSTION AIR REQUIREMENTS

It is imperative that there is sufficient air supply to the stove in order to support correct combustion. The air supply to this appliance must comply with current Building Regulations Part J, Heat Providing Appliances. If another appliance is fitted in an adjacent room it will be necessary to calculate an additional air supply.

The minimum effective air requirement for the IS1700DS is 60.5cm² & for the IS1500DS is 49.5cm². When calculating combustion air requirements for this appliance use the following equation:

550mm² per each kw of rated output above 5kw should be provided, where a flue draught stabiliser is used the total free area shall be increased by 300mm² for each kw of rated output.

Note:

There must not be an extractor fan fitted in the same room as the stove as this can cause the stove to emit smoke and fumes into the room.

All materials used in the manufacture of air vents should be such that the vent is dimensionally stable, corrosion resistant, and no provision for closure.

The effective free area of any vent should be ascertained before installation. The effect of any grills should be allowed for when determining the effective free area of any vent.

Air vents should be positioned so that they are not liable to blockage.

Air vents direct to the outside of the building should be located so that any air current produced will not pass through normally occupied areas of the room.

An air vent outside the building should not be located less than the dimensions specified within the Building Regulations and B.S. 8303: Part 1 from any part of any flue terminal. These air vents must also be satisfactorily fire proofed as per Building Regulations and B.S. 8303: Part 1.

Air vents in internal walls should not communicate with bedrooms, bedsits, toilets, bathrooms or rooms containing a shower.

Air vents traversing cavity walls should include a continuous duct across the cavity. The duct should be installed in such a manner as not to impair the weather resistance of the cavity.

Joints between air vents and outside walls should be sealed to prevent the ingress of moisture. Existing air vents should be of the correct size and unobstructed for the appliance in use.

If there is an extraction fan fitted in adjacent rooms where this appliance is fitted, additional air vents may be required to alleviate the possibility of spillage of products of combustion from the appliance/flue while the fan is in operation. Refer to B.S. 8303 Part 1.

Where such an installation exists, a test for spillage should be made with the fan or fans and other appliances using air in operation at full rate, (i.e. extraction fans, tumble dryers) with all external doors and windows closed.

If spillage occurs following the above operation, an additional air vent of sufficient size to prevent this occurrence should be installed.

Especially Airtight Properties:-

If the stove is being fitted in a property where the design air permeability is less than 5m³ / (h.m²) (normally newer properties built from 2006), then a permanent ventilation must be fitted to provide 550mm² of ventilation for each kW of rated output. If a draught stabiliser is also fitted then the requirement is 850mm² per kW of rated output.

EXTERNAL DUCTED AIR

Where required the combustion air supply can be ducted from outside.

It is recommended to bring the air supply for the stove into the house using a 3" plastic pipe. Where the pipe meets the outside wall make sure a vent cover is fitted properly to ensure no rodents can enter via the vent pipe.

The vent pipe should be located to prevent the ingress of moisture and in a location where it will not get blocked with leaves or any other debris. As wind effects can create suction and pressure zones of opposite sides of the dwelling it is recommended to run the air vent from opposite poles (North, South, East & West) of the dwelling and tee off for the air supply to the stove. This should negate the effect of suction and pressure zones. See Fig.8 for an illustration of how the vent pipe should be configured.

'HETAS product approval covers this appliance when installed in accordance with the manufacturer's instructions and relevant standards. As there is currently no standard for Ducted Combustion Air Supply this does not fall within the remit for HETAS product approval. Responsibility for the specification of this and for appropriate manufacturer's instructions is carried by the appliance manufacturer, as allowed for under the Building Regulations.'

Fig.8

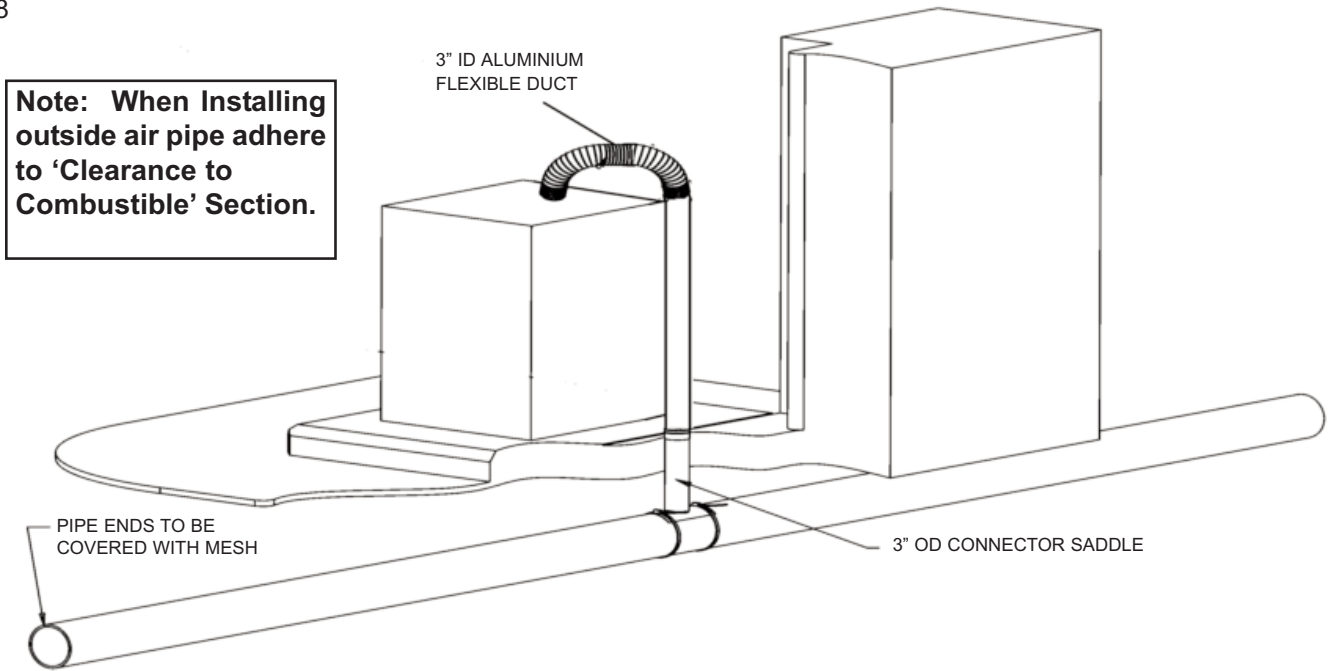

HEAT RECOVERY VENTILATION

Where a stove is to be installed in a dwelling with *Heat Recovery Ventilation (HRV)* a number of precautionary measures must be undertaken:

Where the product is to be installed with a Mechanical Ventilation, the stove must be connected to an external air supply, The ductwork for the external air supply must be no longer than 6 metres and the air inlet terminal to the ductwork must have a cross sectional area of at least 80cm².

LOCATION

There are several conditions to be considered in selecting a location for your Solis stove.

- a. Position in the area to be heated, central locations are usually best.
- b. Allowances for proper clearances to combustibles.
- c. Allowances for proper clearances for maintenance work.

CLEARANCES TO COMBUSTIBLES

This appliance must be installed in a recess and the recess should not contain any combustible material. Wood battens and plaster board should not be used within the clearance to combustibles. The minimum clearance to combustibles required is as follows:

From the Top	400mm
From the Sides	600mm
From the Front/Back	1400mm
Combustible Front - Floor Level	225mm
Combustible Side	600mm

Fig.9

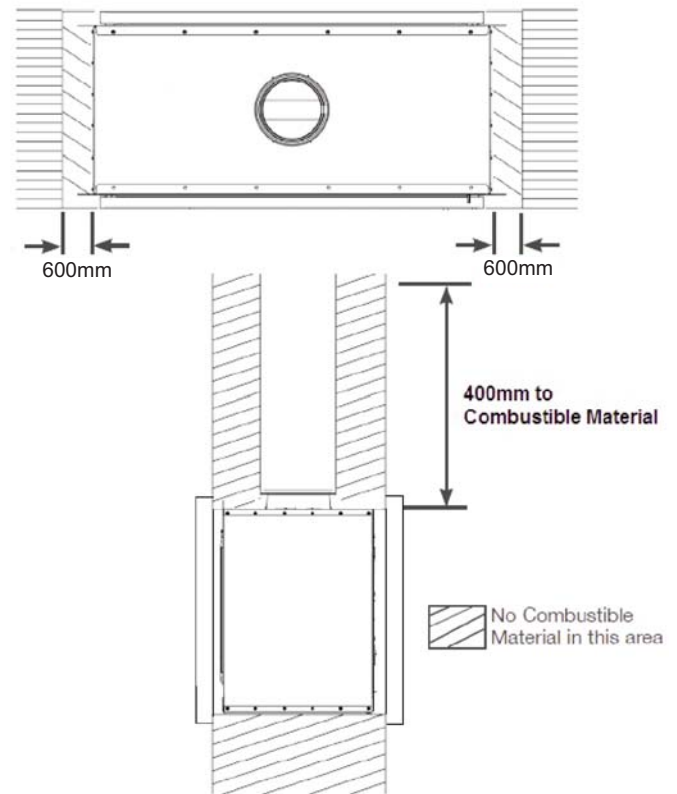

FLOOR PROTECTION

It is recommended that the appliance is installed on a solid, level, concrete base of non combustible hearth conforming to the current Building Regulations and must extend 225mm in front of the appliance. This will provide protection from sparks and embers which may fall out when stoking on refuelling.

Fig.10

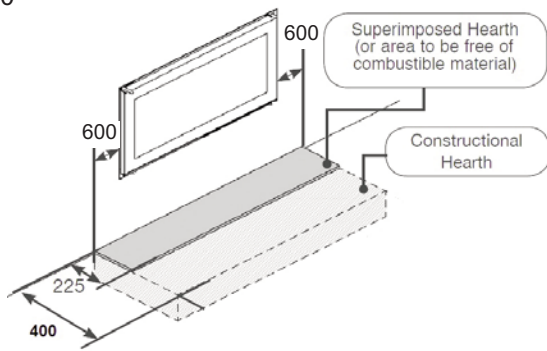

WARM AIR DUCTING SYSTEM

This appliance can be fitted to a Warm Air Ducting System that will allow to distribute warm air to elevated positions within the room or other parts of the building.

All duct runs must always rise from the appliance and be as straight as possible, with the minimum of bends to ensure a good airflow. All ducts should be suitably supported along the full length.

If the appliance is installed in a property with a gas appliance fitted consideration should be given to the ventilation air requirements of the gas appliance, and an assessment made by a suitably trained and appropriately qualified gas engineer.

Ducts must not be connected to areas designated as a protected stairway as defined by the Local Building Regulations.

Where ducts pass through walls or ceilings they must be adequately supported and the space around them filled with suitable non-combustible filler.

It is recommended to fit a CO alarm in the area where the ducts exit in addition to the one required to be placed in the room with the appliance.

POSITIONING OF THE WARM AIR DUCT

The following must be adhered to when locating the warm air duct system:

- * The air duct must not touch any combustible materials within 550mm of the back of the appliance.
- * Take care when routing the duct to ensure it is not deformed and restricting the airflow.
- * Due to the possible high temperature of the ducts, combustible material must be placed no closer than 100mm to the surface. The duct exits and grills must only be placed in a non-combustible wall panel.
- * Protect or place the exit ducts at a high level, as the grill surfaces can become very hot when in use.
- * Use a suitable guard if the exit is at low level to prevent touching or obstruction.
- * Do not place combustible items near the operating duct exit.

FITTING THE WARM AIR DUCTS TO STOVE

1. Remove the cover plates on the top of the firebox.
2. Fit the warm air duct spigots to the top of the firebox using self tapping screws (see Fig 11).
3. Position the vents as advised in the previous section.
4. Fit the flexible pipe to the spigots & vents and secure with the clamp bands.

Fig.11



WARM AIR DUCT SPIGOTS

STOVE DIMENSIONS

IS100 DS MODEL

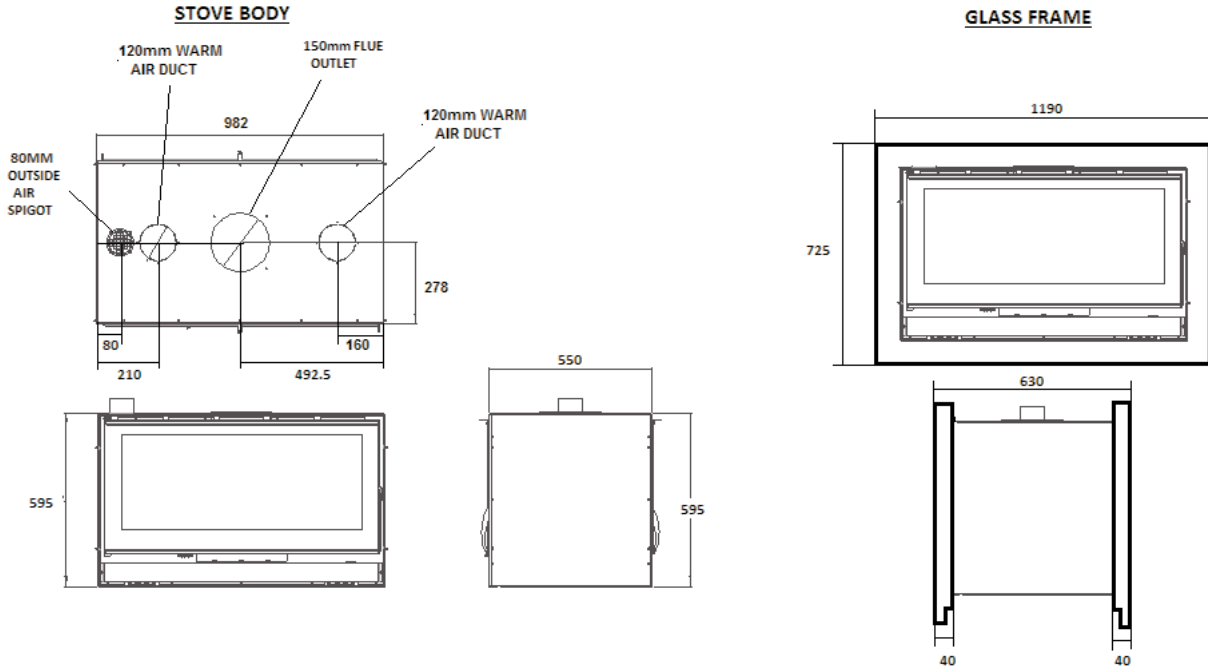

IS80 DS MODEL

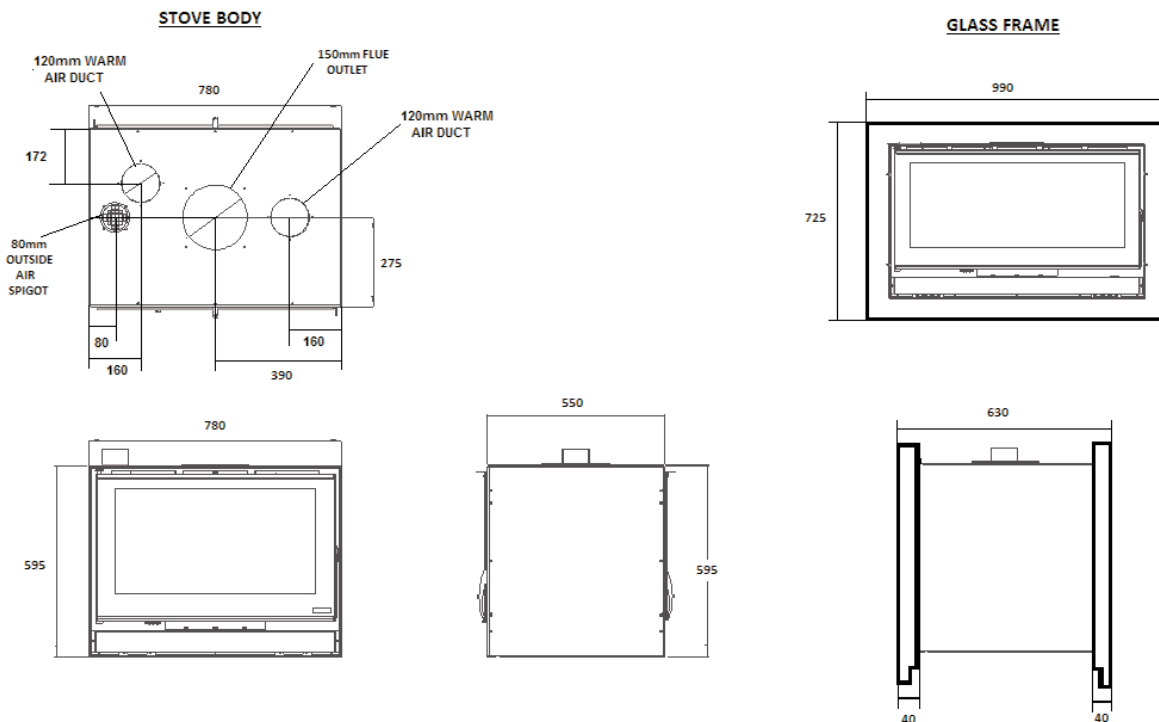

Note: Dimensions stated are in millimetres unless otherwise stated and may be subject to a slight +/- variation.

COMMISSIONING AND HANDOVER

On completion of the installation allow a suitable period of time for any fire cement and mortar to dry out, when a small fire may be lit and checked to ensure the smoke and fumes are taken from the stove up the chimney and emitted safely to the atmosphere. **Do not run at full output for at least 24 hours.**

Ensure that the operating instructions for the stove are left with the customer. Ensure to advise the cus-

tomers on the correct use of the appliance and warn them to use only Wood.

Advise the user what to do should smoke or fumes be emitted from the stove. The customer should be warned to use a fireguard to BS 8432: 2010 in the presence of children, aged and/or infirm persons.

OPERATION

Check that all dampers and catches are operating correctly and ensure that all flue connections are thoroughly sealed.

AIR CONTROLS

The Solis Stove has two independent air controls (See Fig. 12)

1. The primary air control lever is the left hand lever located under the fire door. Push right to open and left to close.
2. The secondary air control lever is the lever located above the fire door. Push right to open and left to close.

Note: The controls may be hot when the stove is in operation, use the tool provided to adjust the controls when the stove is hot.

Fig.12

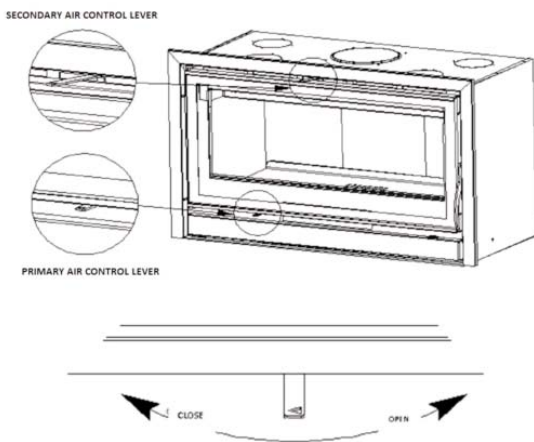

FAN OPERATION

The stove is fitted with convection blowers that blow hot air into the room through the air vents located above the fire door when the stove is in operation.

The blowers have two settings (see Fig. 13)

I - Low speed setting

II - High speed setting

When in the OFF(O) position, the fans will be turned off but the built-in safety thermostat will be able to activate them at any time when the temperature within the lower casing of the stove has reached 50 degrees C in order to protect the electric components.

When the warm air ducting system is connected, the air vents above the fire door can be closed off using the operating tool by catching the vent hook with the tool & pulling the vent closure plate towards the front of the unit (see Fig 14).

Fig.13



Fig.14



RECOMMENDED FUELS

All fuels should be stored under cover and kept as dry as possible prior to use.

This appliance has been tested using seasoned wood logs and **ONLY WOOD LOGS, WITH A MOISTURE PERCENTAGE OF LESS THAN 20%, MUST BE USED IN THIS APPLIANCE.**

Do not use fuels with a Petro-coke ingredient as this may cause the grate to overheat, causing damage. Reduced outputs will result when fuels of lower calorific values are used. Never use gasoline or gasoline type lantern fuel, kerosene, charcoal lighter fluid or similar liquids to start or freshen up a fire in this heater. Keep all such liquid well away from the heater at all times. Operate the stove only with the fuelling door closed except for re-fuelling.

TECHNICAL DATA

	IS100DS	IS80DS
Nominal Output: (kW)	15.3kW	14kW
Mean Flue Gas Temperature °C	267	267
Typical refuelling intervals to obtain nominal outputs:	0.72 hrs	0.72 hrs
CO at 13% O ₂	0.10%	0.10%
Gross Weight	150kgs	125kgs
Flue Outlet	150mm (6")	150mm (6")
Efficiency	79%	79%
Flue Draught	12Pa	12Pa
Log Size	650mm	550mm

Model	Energy Efficiency Class	Heat Output to Room	Heat Output to Water	Energy Efficiency Index	Preferred Fuel	Nominal Heat Output	Net Efficiency
IS100DS	A	15.3	N/A	105.55	Wood	15.3	79
IS80DS	A	14.0	N/A	105.55	Wood	14.0	79

LIGHTING

Before lighting the stove check with the installer that the installation work and commissioning checks described previously have been carried out correctly and that the chimney has been swept clean, is sound and free from any obstructions. As part of the stoves commissioning and handover the installer should demonstrate how to operate the stove correctly.

LIGHTING THE STOVE

1. Open the fire door and open the primary & secondary air inlets by pushing the two air control levers to the right.
2. Cover the grate with crumpled pieces of paper and lay 10-12 pieces of kindling on top of the paper towards the back of the firebox.
3. Ignite and close the fire door.
4. When the kindling is well alight open the fire door and add more kindling of a larger size to sustain the fire. Close the fire door.
5. When a hot fire bed is established, close the primary air inlet fully and add larger pieces of wood.
6. When well lit, adjust the secondary air control as required depending on the heat output required. The exact settings will depend on the draught conditions of the chimney to which the unit is connected.

Depending on the quality of the firewood, it may be necessary to open the primary air inlet to sustain the desired burn rate, but during normal operation, the primary air lever should not be opened by more than 10mm.

REFUELLING

Before opening the fire door, open the air controls fully as this will help to eliminate any smoke or fly ash resident in the combustion chamber. Open the fire door slowly, add fuel to fire, close fire door and re-set the air controls to the required setting.

SLOW BURNING

Slow burning will cause the window glass to blacken and should not be used for a long period. It should only be done after the fire has been established and been running at nominal output for a period of time. For a prolonged slow burn, fill the firebox of fuel up to a maximum height just below the top of the fire fence at the front of the door opening. Close the air controls.

DISPOSAL OF ASHES

Your stove is provided with an ashpan which should be emptied every day.

If ashes are allowed to build to grate level you could damage the grate by overheating. We recommend that you remove ashes when the stove is thoroughly cooled.

Ashes should be placed in a metal or other non-combustible container with a tight fitting lid. The closed container of ashes should be placed on a non-combustible material, pending final disposal. If ashes are buried in soil, or otherwise dumped they should be retained in the closed container until they are thoroughly cooled.

Open the fire door and remove the ashpan, see Fig 15. Close the fire door. When the ash is disposed of replace the ashpan.

Fig.15



ASHPAN

MONTHLY MAINTENANCE

Cleaning Stove Flue Pathways

It is recommended that the flue pathways in the stove are cleaned on a monthly basis (or less depending on the soot build-up created by the fuel being used) and the chimney cleaned annually. To access the chimney pathways:

1. Remove the fire grate by lifting it up and out of the firebox.
2. Lift up the back of the bottom baffle and push it back to release it from the side locating tabs - see Fig 16. Remove the baffle from the firebox.
3. Lift off the two brick retaining brackets - see Fig 17.
4. Remove the side bricks by angling out the edge closest to the centre of the firebox - see Fig 18.
5. Bend the clips on the top baffle that protrude through the front frame to allow for their removal from the front frame - see Fig 19.
6. Remove the top baffles by angling up on one side to allow to drop into the firebox.

Fig.16

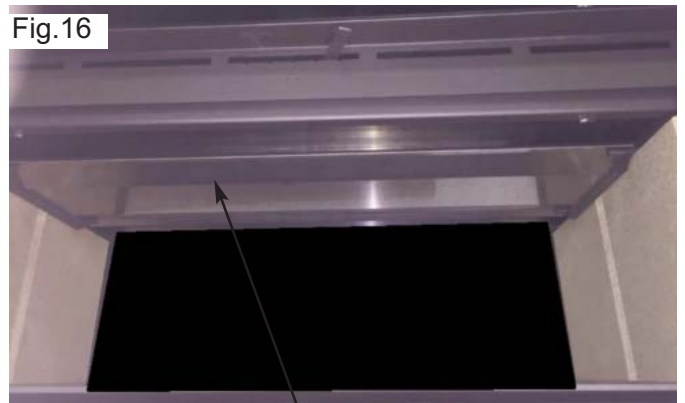

BOTTOM BAFFLE

Fig.17

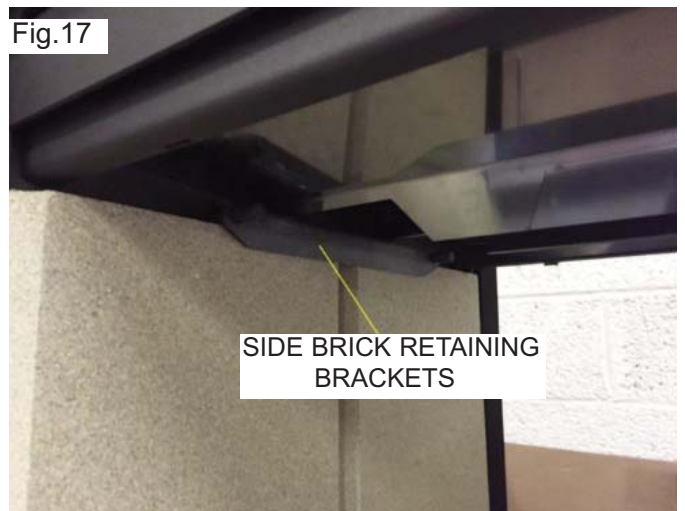

SIDE BRICK RETAINING BRACKETS

Fig.18



Fig.19



PERIODIC MAINTENANCE

Rope Seal Replacement

Over time, the fire door latch can loosen due to the continued compression and hardening of the seal between the door and the front frame. It is recommended that the rope seals are changed at least every two years or sooner if the seal loses its integrity.

CHIMNEY CLEANING

The chimney should be cleaned twice annually or if the stove is not used for a prolonged period during the summer period, it should be cleaned prior to commencement of usage. The chimney can be cleaned through the stove depending on the flue configuration and the flue liner should be cleaned in accordance with manufacturer's instructions. Always use a brush with plastic bristles that is the correct size to reach all areas of the flue.

GLASS CLEANING

The stove glass will self-clean when there is sufficient heat generated by the burning fuel i.e. when the unit is operated at the maximum air settings. If a build-up of creosote occurs on the glass it may be due to low draft conditions, poor quality fuel or operating the stove at the minimum air settings for long periods of time. The glass should be cleaned when cool and cleaned with a non-abrasive cloth using warm soapy water. For stubborn deposits, a grade 0 steel wool can be used whilst taking care not to scratch the glass with any coal/ash deposits.

CLEANING A MATT BLACK/SENOTHERM STOVE

Cleaning should be done when the stove is cold by removing any dust or dirt using a dry cloth. Do not use any water on the matt black/senotherm finish as this will cause it to rust.

PROLONGED PERIODS OF NON USE

If the stove is to be left unused for a prolonged period of time then it should be given a thorough clean to remove ash and unburned fuel residues. To enable a good flow of air through the appliance to reduce condensation and subsequent damage, leave the air controls fully open.

It is important that the flue connection, any appliance baffles or throat plates and the chimney are swept prior to lighting up after a prolonged shutdown period.

WARNING NOTE:

Properly installed, operated and maintained this stove will not emit fumes into the dwelling. Occasional fumes from the de-ashing and re-fuelling may occur. However, persistent fume emission is potentially dangerous and must not be tolerated. If fume emission does persist, then the following immediate action should be taken:

- (a) Open doors and windows to ventilate room.
- (b) Let the fire out or eject and safely dispose of fuel from the stove.
- (c) Check for flue or chimney blockage and clean if required.
- (d) Do not attempt to relight the fire until the cause of the fume emission has been identified and corrected. If necessary seek expert advice.

The most common cause of fume emission is flue-way or chimney blockage. For your own safety these must be kept clean at all times.

FIRE SAFETY

To provide reasonable fire safety, the following should be given serious consideration.

1. Do not over fire the stove.
2. Over-firing will also damage the painted finish.
3. Install a smoke detector in the room.
4. A conveniently located class A fire extinguisher to contend with small fires resulting from burning embers.
5. A practical evacuation plan.
6. A plan to deal with a chimney fire as follows:-
 - (a) Notify the fire department.
 - (b) Prepare occupants for immediate evacuation.
 - (c) Close all openings into the stove.
 - (d) While awaiting the fire department watch for ignition to adjacent combustibles from overheated flue pipe or from embers or sparks from the chimney.

GLASS REPLACEMENT

- (a) Remove the fire door by opening the door slightly & lifting it up to detach from the bottom hinge.
- (b) Remove the top glass retaining bracket by loosening the two screws & nuts - see Fig 20.
- (c) Remove the glass.

Fig 20

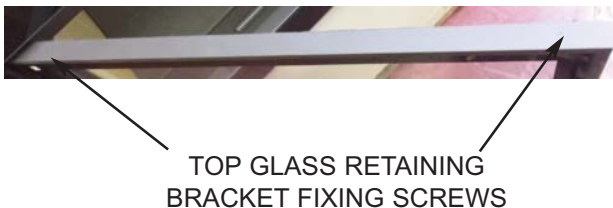

CO ALARM

The fitting of CO Alarms in the same room as the appliance is a compulsory requirement under current Building Regulations. For ROI an additional CO Alarm must be fitted either inside each bedroom or within 5 metres of the bedroom door, refer to Building Regulations Part J. Further guidance on the installation of a carbon monoxide alarm is available in BS EN 50292:2002 and from the alarm manufacturers instructions.

Provision of an alarm must not be considered a substitute for either installing the appliance correctly or ensuring regular servicing and maintenance of the appliance and chimney system.

WARNING:-

If the CO Alarm sounds unexpectedly:-

- 1. Open Doors and windows to ventilate the room and then leave the premises.**
- 2. Let the fire go out.**

ELECTRICAL DIAGRAM

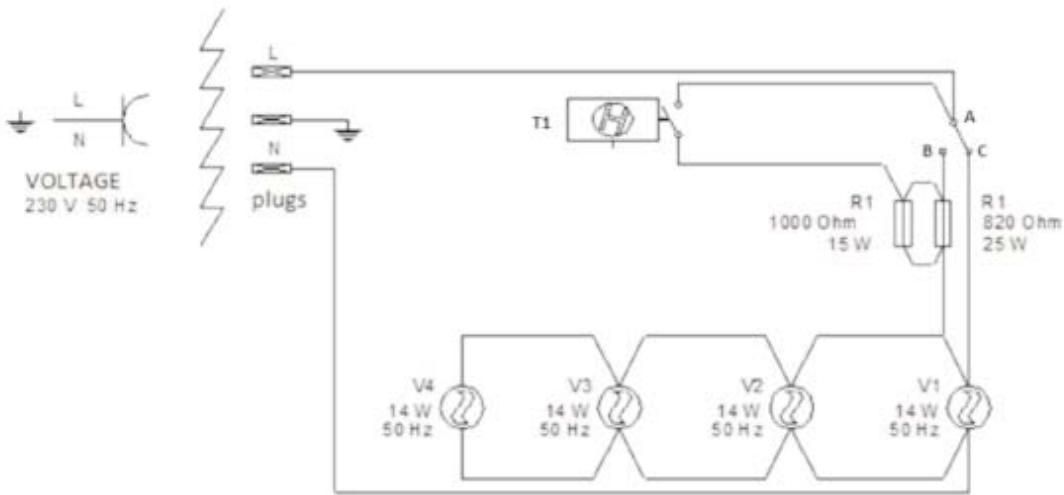

LEGEND:

- A - "O" Switch Position
- B - "I" Switch Position
- C - "II" Switch Position
- T1 - 50 C Snap Switch
- V - Convection Fans

IS100DS/IS80DS - EXPLODED VIEW

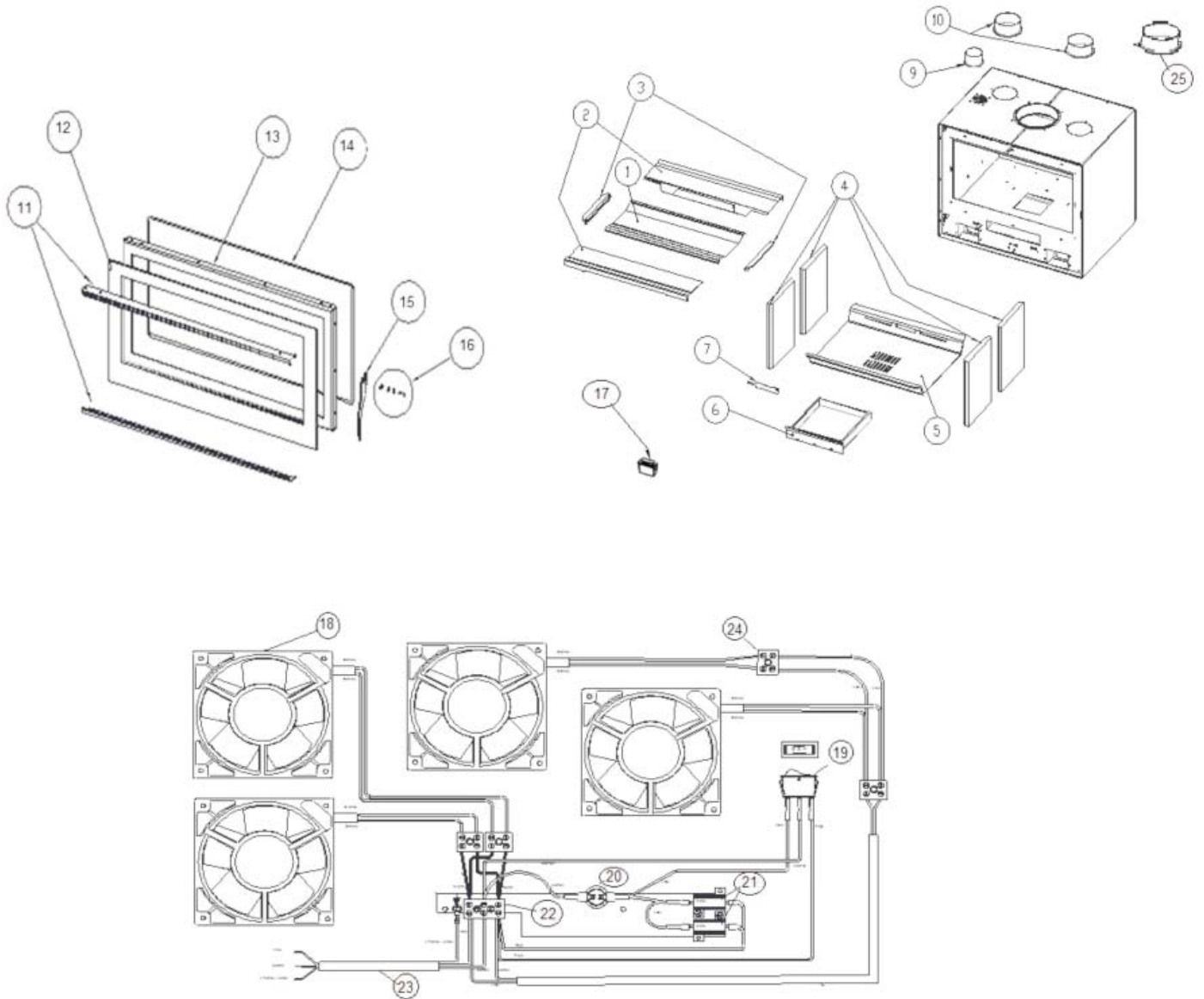

NO	DESCRIPTION	PART CODE	
		I100DS	I80DS
1	PRIMARY BAFFLE	DEFMETKR100DC	DEFMETKR80DC
2	SECONDARY BAFFLE	DEFSUPKR100DC	DEFSUPKR80DC
3	BAFFLE FIXING BRACKETS	SUJLATKR100DC	SUJLATKR80DC
4	SIDE BRICKS	LATVERKRDC	
5	GRATE	BFKR100DC	BFKR80DC
6	ASHPAN	CAJCENKR	
7	AIR CONTROL ROD	MANO	
9	EXTERNAL AIR SPIGOT	E2026	
10	WARM AIR DUCT SPIGOT	E2025	
11	GLASS FIXING BRACKET	JUN100	JUN80
12	GLASS	20CRC100DEK	20CRC80DEK
13	FIRE DOOR	PTAKR100	PTAKR80

NO	DESCRIPTION	PART CODE	
		I100DS	I80DS
14	DOOR ROPE SEAL	CORD8	
15	DOOR HANDLE	MANETA	
16	DOOR HANDLE FIXING	KITMAN	
17	SWITCH BLANK	20ELC1	
18	FAN	A1819	
19	FAN SWITCH	INTER	
20	SAFETY THERMOSTAT	A99151	
21	ELECTRICAL RESISTOR	A105341	
22	6 WAY TERMINAL BLOCK	FF550SA0673	
23	MAINS CABLE	MANGUERA	
24	4 WAY TERMINAL BLOCK	FF51100036	
25	FLUE ADAPTOR	COLL200150	
	GLASS FRAME	MCRIS100	MCRIS80

Manufactured by
Waterford Stanley Ltd.,
Unit 401-403, IDA Industrial Estate, Cork Road,
Waterford, Ireland.
Tel: (051) 302300 Fax (051) 302315

